

=25°C (unless otherwise specified)

		=25°C		
		=100°C		
		=25°C		
			±	
		=25°C		
		=25°C		
				°C

			°C/W
			°C/W





--	--

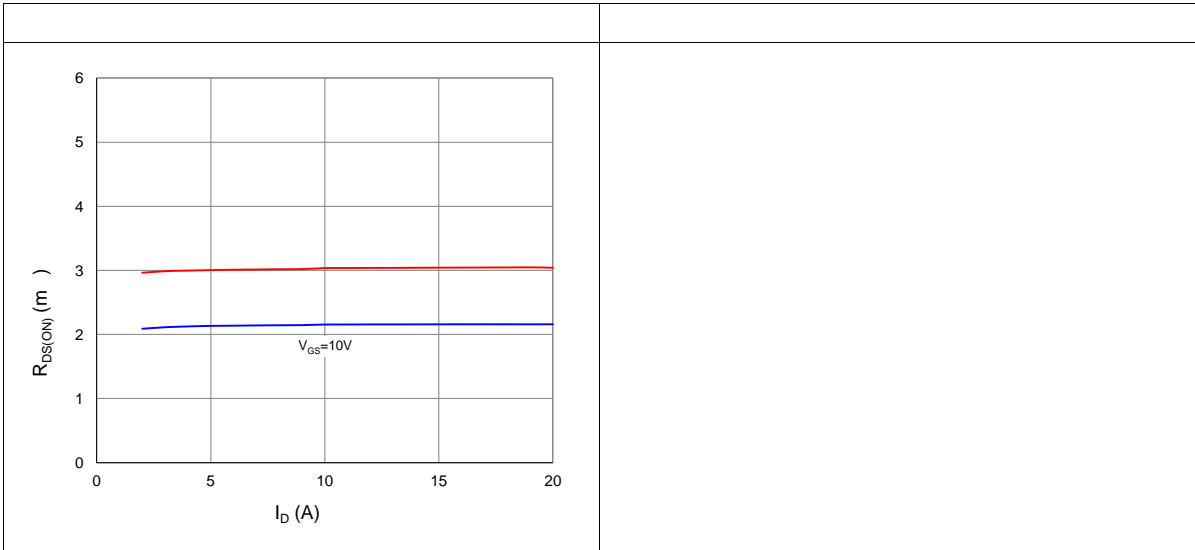

--	--

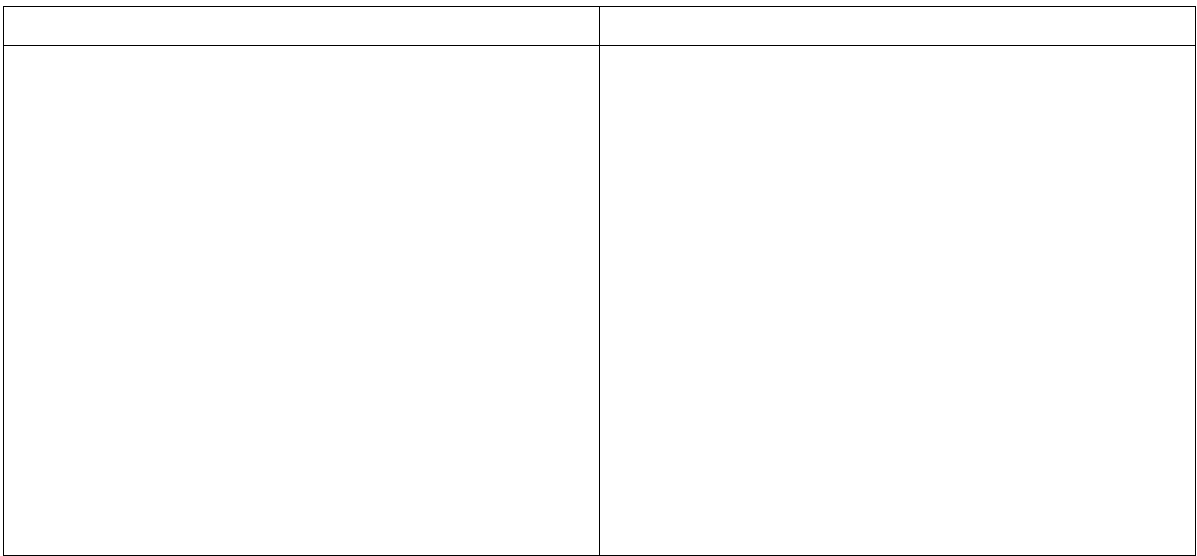
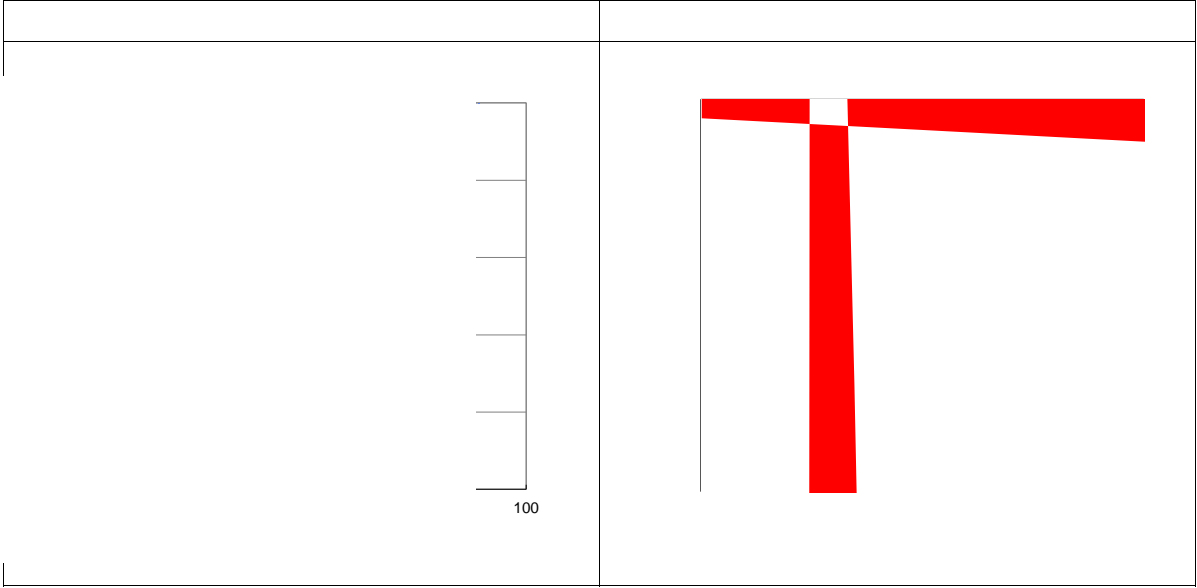

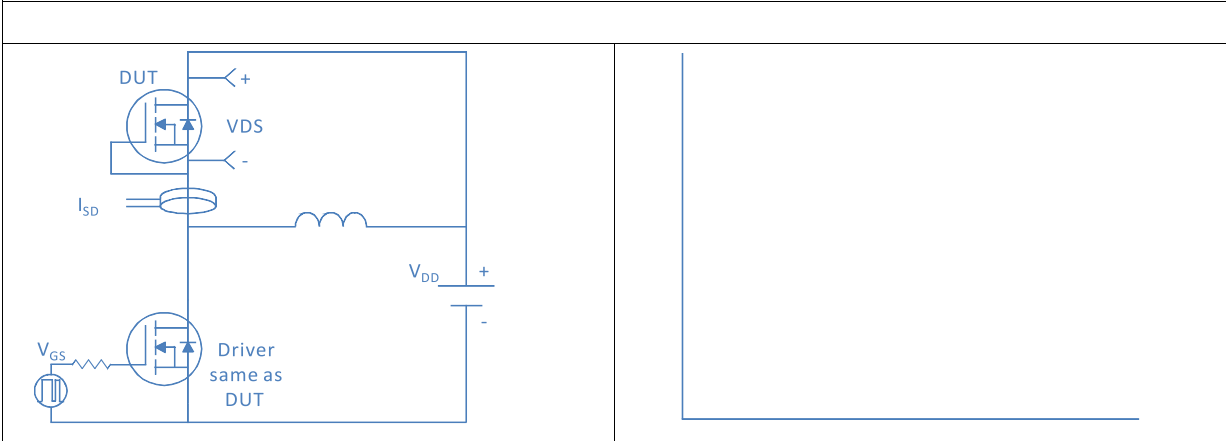
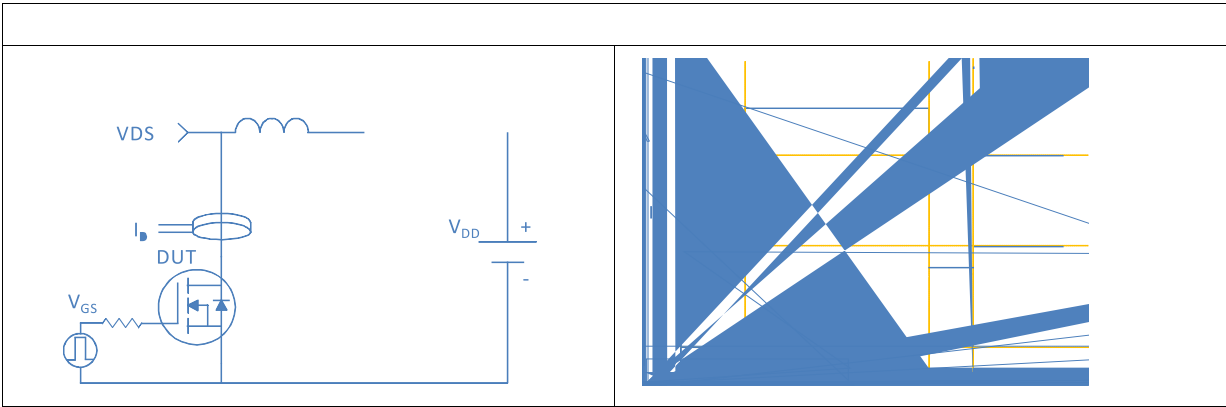
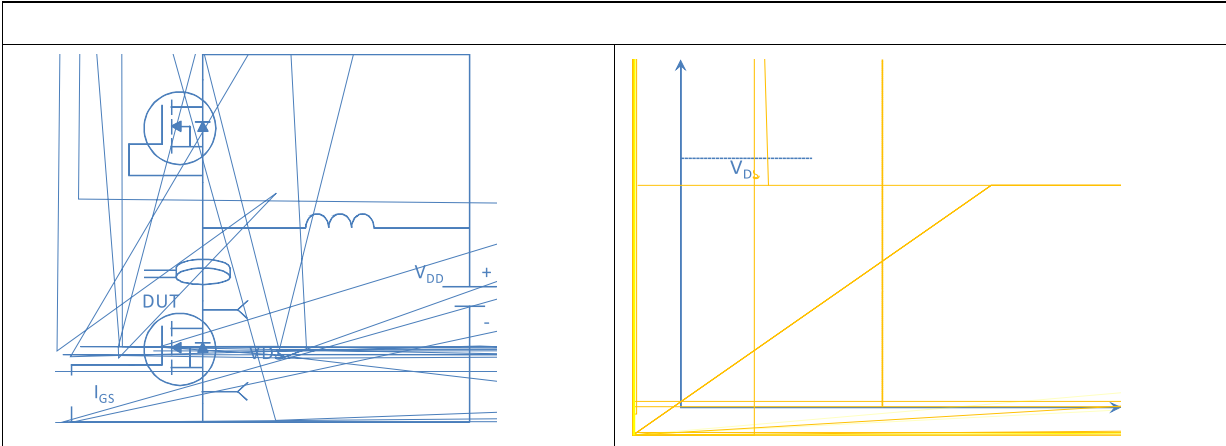
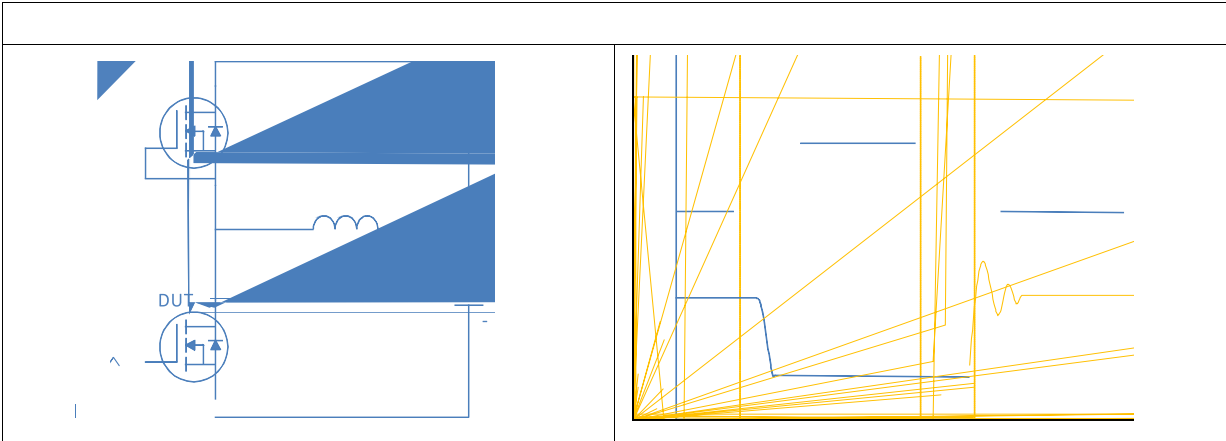

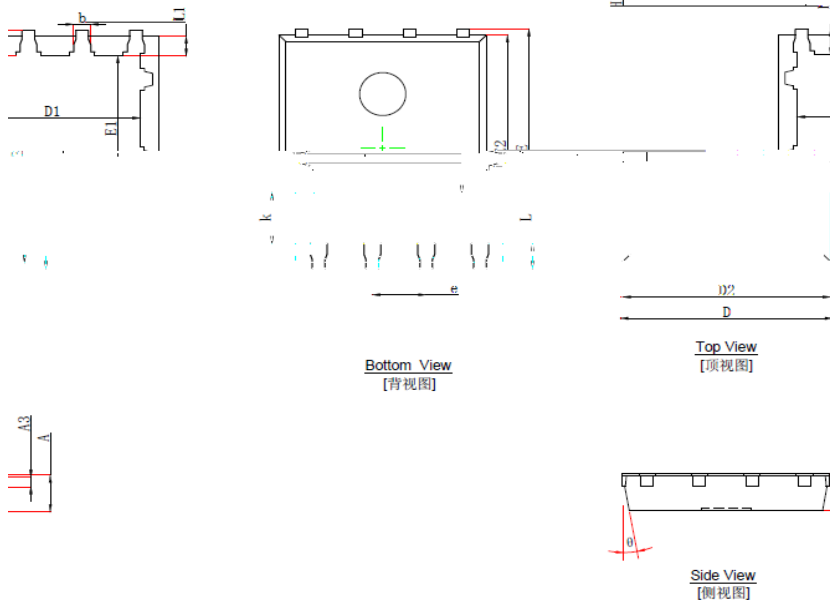

Symbol	Dimensions In Millimeters		Symbol	Dimensions In Inches	
	mm	mm		in	in
	0.075	0.045	A	0.003	0.002
	0.012 ± 0.001		A1	0.0004 ± 0.0001	
	0.164	0.202	B	0.006	0.008
	0.258	0.261	C	0.010	0.010
	0.162	0.152	D	0.006	0.006
	0.135	0.143	E	0.005	0.006
	0.182	0.137	D/2	0.007	0.005
	0.022	0.022	F	0.001	0.001
	0.040	0.035	k	0.002	0.001
	0.015	0.010	b	0.001	0.000
	0.020 ± 0.001		c	0.001 ± 0.000	
	0.010	0.005	L	0.000	0.000
	0.017	0.023	L1	0.001	0.001
	0.011	0.015	L2	0.000	0.000
	0	0	0	0	0